



# Installation & Operation Manual

5005001B  
Version 6.0

**AUDI**  
**AHRI**  
MEMBER  
Air-Conditioning, Heating,  
and Refrigeration Institute

# TABLE OF CONTENTS

• <b>Warranty Registration</b>	<b>3</b>
• <b>Introduction</b>	<b>4</b>
• <b>Water Chemistry Maintenance</b>	<b>5</b>
• <b>Installation</b>	
○ <b>Location of Heater</b>	<b>6</b>
○ <b>Installations Below Pool Level</b>	<b>7</b>
○ <b>Plumbing Sequence</b>	<b>7</b>
• <b>Heat Pump Features</b>	<b>8</b>
• <b>Heat Pump Operation</b>	
○ <b>Control On/Off</b>	<b>9</b>
○ <b>Pool/Spa Modes</b>	<b>10</b>
○ <b>Changing Set Point Temperature</b>	<b>10</b>
○ <b>Sub-Menu Access</b>	<b>11</b>
○ <b>Remote Automation/Remote T-Stat</b>	<b>11</b>
○ <b>Remote HP/ Remote off</b>	<b>11</b>
○ <b>Heater Running Time</b>	<b>12</b>
○ <b>Keypad Lockout</b>	<b>12</b>
○ <b>Defrost Cycle</b>	<b>12</b>
○ <b>Condensation Drainage</b>	<b>12</b>
○ <b>Heat/Cool Operation</b>	<b>13</b>
○ <b>Heat/Cool with External Remote</b>	<b>14</b>
○ <b>Care &amp; Maintenance</b>	<b>16</b>
○ <b>Blank Page</b>	<b>15</b>
○ <b>Cleaning</b>	<b>16</b>
○ <b>Winterizing</b>	<b>16</b>
• <b>Troubleshooting</b>	<b>17</b>
• <b>Wiring Diagram</b>	<b>19</b>
• <b>Blank Page</b>	<b>20</b>
• <b>Service</b>	<b>21</b>



## **WARNING:**



Non-authorized service may not be covered under warranty.

## **REGISTER YOUR WARRANTY ONLINE AT:**

[gulfstreamheatpump.com/register](http://gulfstreamheatpump.com/register)

## **SERVICE**

All warranty service must be handled by an Authorized Service Center. Warranty costs may not be covered if a non-authorized service representative provides service on the unit. Do not return the heater to your dealer, as they do not provide service. Before calling for assistance or service, please check the Troubleshooting section of this manual or call your dealer. This may save you the cost of a non-warranty service call. If you still need help, follow the instructions below.

## **Schedule service on-line at:**

[gulfstreamheatpump.com](http://gulfstreamheatpump.com)

## **Service can also be obtained by calling us at:**

**(239) 567-0009 or (954) 318-6900**

For faster service, please provide: a detailed description of the problem, heat pump serial number and purchase date. This information will help us respond properly to your request.

**Keep a copy of the sales receipt with the date of purchase.**

**Proof of purchase will verify in-warranty service.**

**Attention, Warning, & Caution boxes have been placed throughout this manual to help point out important information.**



**Attention** - important information to be aware of



**Warning** - action that may void warranty



**Caution** - safety issues

## Introduction

Congratulations on purchasing the most advanced high efficiency, microprocessor-controlled pool and spa heat pump available. Your heater has been manufactured with the best state-of-the-art quality control equipment available today to ensure the highest quality product delivered to your door. A heat pump pool heater is a highly efficient, cost effective method of pool heating. Proper operation and care will result in many years of swimming enjoyment and pleasure.

Your new pool heater is a self-contained unit designed specifically for swimming pool and spa heating. It utilizes the sun's free energy by extracting heat from the sun-warmed air and transferring it efficiently to the pool water. Because your pool heater moves the free heat from the outside air to the pool, rather than create heat, as a fossil fuel or electric resistance heater does, it can heat your swimming pool or spa for up to 80% less cost than these other less efficient methods.

As with all pool heating methods, you are advised to utilize a pool cover at night and when the pool is not in use. The pool cover should be used if the night temperature is 15°F (8°C) less than the desired pool temperature. This will keep evaporation, the greatest source of heat loss, to a minimum therefore greatly reducing the overall pool heating costs. During warmer weather, the pool cover may not be required.

Your pool and spa heater combines simplicity with trouble-free performance. As with most appliances, an understanding of proper operation of the heater is important. Proper installation and operation increases efficiency and reduces heating costs. Your pool heater is designed with features that make it simple to operate, maintain and service. This manual will provide you with the information needed to properly operate and maintain your heater.



### **ATTENTION:**



**Register your warranty at [gulfstreamheatpump.com/register](http://gulfstreamheatpump.com/register)  
or be sure to mail in the Warranty Registration Card  
that is provided with your heater.**

Also, please take a moment and write down the following information. If you should ever need to call us, we may ask for this information:

Serial Number: \_\_\_\_\_ Purchase Date: \_\_\_\_\_

Dealer Name/ Phone #: \_\_\_\_\_

## WATER CHEMISTRY MAINTENANCE

Not only is the water chemistry of your pool or spa important to the health of you and your family, it may also directly affect the life of your heater. If the water chemistry is improperly maintained or if the chemicals are improperly introduced into the water, this may damage the heater's internal components and could eventually cause a leak, rendering the heater inoperable.



### WARNING:



**Do not store corrosive pool chemicals near the heater!**

### Standard Water Quality Table:

Test	Normal Range
PH Level	7.4 to 7.8
Chlorine Concentration	1 to 3 PPM
Total Alkalinity	80 to 120 PPM
Total Dissolved Solids	Below 2400 PPM
Calcium Hardness	200 to 300 PPM

The location of the chemicals' introduction to your system is also critical to the heater's life. If an automatic in-line chlorinator is used (including a salt system), it must be located downstream of the heater. A Trap/Check Valve may also be installed between the chlorinator and the heater to prevent chlorine return into the heater.



### WARNING:



**Never add chemicals into the pool skimmer.**

Never leave any type of solid chlorine in the pool skimmer. This will cause a high concentration of chlorine to enter your pool equipment, causing premature corrosion.



### WARNING:



Make sure that there are **NO SPRINKLER HEADS** that spray near or directly on the heater. This will cause expedited corrosion of the unit.

# INSTALLATION

## LOCATION OF HEATER

The unit is designed for outdoor installation with maximum air flow. This unit should not be placed in a totally or partially enclosed area, such as shed or garage. This will cause recirculation of cold discharge air back into the evaporator coil and will greatly reduce heating capacity and efficiency of the unit. Any restriction of air flow may damage the unit and will not be considered a manufacturer's defect.

**\*\*If the unit is installed at the edge of a roofline, make sure the roof has a rain gutter to prevent water from the roof pouring into the heater.**

The heater should be located as close to the existing pool pump and filter. This will minimize system pressure and latent heat losses.

**\*\*At least 4 feet clearance should be allowed above the unit for unrestricted air discharge.** Your heater features an up-flow fan for ultra-quiet operation. Air is pulled through the evaporator coil and discharges through the top of the grill. The unit must not be installed under a porch or any kind of overhang with less than 4 ft of clearance.

**\*\*All sides of the heater should have at least 12 inches of clearance to allow enough air to flow through the evaporator coil for optimal heating.** Restricting one side of the evaporation coil is permitted, however, it will cause a decrease in performance. A clearance of 18 inches is optimal.

The unit should be placed on a flat surface, preferably on a concrete or fabricated pad. The surface should have a slight grade so condensation will drain off the pad. The unit should be completely isolated from the building foundation or wall; this will prevent the possibility of vibration sound transmitting into the building.

For areas where tie downs are required, see the placement recommended in Figure HS1.

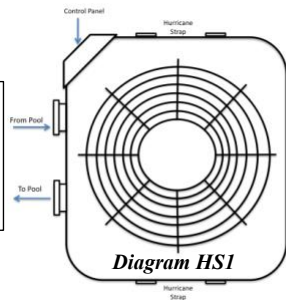

## Installations Below Pool Level

When installing a heater below the pool level (and with some solar heaters), adjustment to the pressure switch must be completed or the manufacturer may require an external flow switch. This is to prevent the pressure switch from falsely indicating water flow due to high head pressure of the water. Failure to adjust the pressure switch may cause the unit to activate without water flow. The unit may go into "WATER FLOW LOCKOUT". You may install the flow switch on the inlet or outlet side of the plumbing. Wire the flow switch into the space marked WPS located on the bottom right corner of the board. (See Diagram FS1).

### Plumbing Sequence

**Pool Pump→ Filter→ Heater→ Solar→ Chlorination System(s)→ Pool→**

Rigid PVC piping is recommended and all joints secured with PVC glue. Installation MUST conform to all local codes. Make sure water-flow is correct (30-70 GPM). Keep piping away from areas that may be tripped over or stepped on when operating heater or servicing.

Try to keep elbows and piping to a minimum to avoid flow restrictions. We use a full-flow heat-exchanger, so no external bypass is required up to 70 GPM.

**Optimal flow rate is 45-50 GPM.**

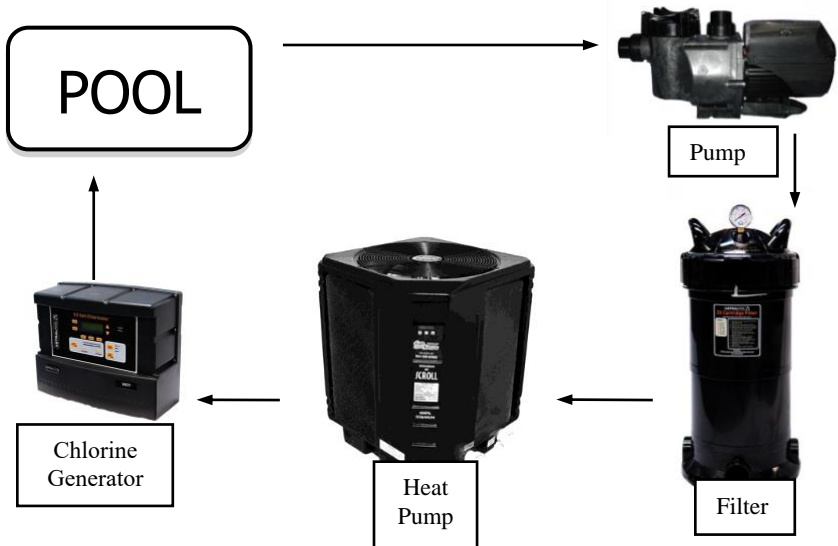

## HEAT PUMP FEATURES

### CABINET

Your heat pump's cabinet is made from a maintenance-free, rust-free ABS plastic that is UV resistant. It will last for years and any dirt or dust may be wiped away with a cloth. Use only cleaners designed for plastic.



### CAUTION:



DO NOT USE CLEANERS THAT CONTAIN ALCOHOL.

### CONTROL

State-of-the-art Blue LCD readout control display. Displays mode and temperature of the water for ease of operation. No programming to learn. Dual thermostats allow user to set pool and spa temperatures. "OFF" mode allows easy way to shut off heater. The control is self-diagnostic and will display a fault if there is a problem. Other features include: lockout, spa timer, automatic low temperature defrost, remote control capabilities and chiller operation via remote control.

### ULTRA-QUIET

The unit is equipped with a low RPM fan motor in combination with a deep drawn venturi and engineered fan blade to ensure whisper quiet operation.

### HIGH EFFICIENCY

The heat pump utilizes the latest in refrigeration technology to produce the highest efficiency available. This, coupled with our over-sized/enhanced fin evaporator coil, and rifled titanium-tube heat exchanger.

### EASE OF INSTALLATION

The unit is equipped with easy-to-install, hand-tightened unions for a quick and trouble-free installation. The unions will accept 2" PVC piping. The electrical connection is made with one entry directly into the control box for a quick hook-up and a neat appearance.



## TURNING THE HEATER ON

### POWER ON

On initial powering up of the unit, "**LANGUAGE SELECT**" will appear on the display. Select your desired language using the up or down arrows. Next, press "MODE" to select °F or °C in the "**TEMP SCALE**" screen. This menu will be on the display for 30 Seconds, then the display will change to the Operation Menu. From the Operation Menu you can adjust the set point. To adjust Language or Temp Scale again, turn the power off at the breaker. Once turned back on, the board will display the "LANGUAGE SELECT" screen again for another 30 seconds. The factory settings are English / °F.



### ATTENTION:



There is a 120 second time delay upon initiation of a heating cycle. This is to ensure that the critical components do not fail due to short cycling of the heater. A count-down will be provided on the display.

### POWER OFF

To shut your Heat Pump OFF, press the "MODE" button until it reads, "POWER OFF". While in "POWER OFF" the unit will not run. To get out of "POWER OFF", press the "MODE" button until it reads "POOL - HEAT" and you can continue normal operation.



### CAUTION:



When the control is in the "OFF" mode, there is still high voltage to the unit. If you want to turn the unit off for long periods of time, shut the main power off to the unit at the main or disconnect.

## **POOL/SPA MODES**

The control is equipped with two independent thermostats; one for pool temperature and one for spa temperature. This is to allow users to preset a temperature of their choice and switch between the two settings with the "MODE" button located on the control. When water is flowing through the unit and the water temperature meets the specified set point condition, the control will turn off the heater.

If you do not have a spa, you can use the spa thermostat as a second temperature setting if you do not want to maintain full temperature all the time. For instance, if you swim on the weekends only, you can set the temperature back during the week to save costs but maintain a warmer temperature for a shorter recovery time for the weekend.

The display on the control will show the thermostat being used and the operating mode on the top line and the current water temperature on the bottom line. The Standard mode displays are:

"POOL – HEAT", "SPA – HEAT", "POWER OFF".

"POOL-COOL", "POOL- HEAT/COOL", will also be available if enabled in the service menu. Additional programming and wiring may be required for these features to be activated.

## **CHANGING SET POINT TEMPERATURE**

To change the set point temperature, press either the "Up" or "Down" arrow buttons on the control. The display will then show "POOL or SPA TEMPERATURE SET POINT". After adjusting the desired temperature setting, the display will revert to "POOL or SPA – HEAT" on the top line and the pool temperature in numbers with "DEGREES" on the bottom line. After 5 seconds of inactivity, the new set point will be stored in memory. The default factory setting for Pool Temperature is 85° Fahrenheit (F).

## Sub-Menu Access

To access the programming sub-menu (remote t-stat, heat/cool, calibration, load defaults, etc.) press and hold the up arrow and down arrow at the same time until the board displays "Remote T-Stat". Use the MODE button to scroll through the options and use the arrows to change settings.

**If there are issues with the operation of the board, we suggest that you "Load Defaults" to return to factory settings.**

## Sub-Menu Items:

- Remote T-Stat – Allows remote thermostatic control
- Remote Heat/Cool – Allows remote control of chiller\*\*
- Pool Heat /Cool – Unit will automatically switch between chilling and heating\*\*
- Pool Cool – Unit will only operate as a chiller\*\*
- Spa Timer – Timer for the spa thermostat.
- Time Delay – Determines how long countdown will be before engaging the compressor
- Defrost Mode – Air defrost or hot gas defrost\*\*
- Defrost End – Sets the temperature at which the unit begins operation after defrosting
- Evap Calibration – Calibrates the Evap Sensor +/- 10 degrees
- Water Calibration – Calibrates the water temp sensor +/- 10 degrees
- Load Defaults – Takes the board back to factory settings

\*\*The unit must be ordered with special features to use any of the cooling or hot gas defrost features.

## Pool Spa Automation (Remote Controls/ Remote T-Stat)

Attach the low voltage lines from your remote control (dry contacts only) to the heater control board at the terminals marked "Pool Spa T-Stat" (See diagram FS1 below). Access the sub-menu by holding the UP Arrow and Down Arrow at the same time until the board reads "Remote T-Stat Disabled". Press the UP Arrow so that the display reads "Enabled". If left alone, the board will return to the main menu and your remote system is now in control of your heat pump. We are unable to assist with programming of your remote systems.

## Remote HP (Remote ON/OFF Switch)

Spades located on the control board marked Remote HP is a remote on/off switch. To use, attach low voltage wires to the spades marked Remote HP to any dry contact switch or relay. Remove the shunt to enable. When the contact/ relay is closed the heater will run. When open, the heater will remain idle and will not run.

## HEATER RUNNING TIME

The owner is responsible for determining the necessary length of operating time for the pump and heater based upon users particular requirements. Most units are sized to operate during the pool filtering cycle time of 8 to 10 hours daily, providing an even, steady flow of heat. On warmer days, the heater will run less because there will be less heat loss from your pool. The heater is capable of running 24 hours per day, if necessary. When you first run your heater, it may need to run continuously for 24 to 48 hours to get the pool up to the desired temperature. The heater operates most efficiently when operated during the warmest hours of the day.

## KEYPAD LOCKOUT

While in any mode, the user can lockout the keypad by pressing and holding the "MODE" button for 6 seconds. When the keypad "LOCKED" has been enabled, all buttons are disabled and the control will operate in whatever mode it was in when the lockout occurred. Any button pushed while in "LOCKED" will cause the display to show "LOCKED" for 5 seconds. To unlock the Keypad, press and hold the "MODE" button for 6 seconds. The display will show "UNLOCKED" for 5 seconds.

## DEFROST CYCLE

The heater is designed to enter the defrost cycle at ambient air temperatures below 48° Fahrenheit. During this cycle, the unit may shut down and the control will display "DEFROSTING" until the ambient air temperature rises above frosting conditions. "Reverse Cycle Defrost" in Heat/Cool models is available – This allows units to operate in the mid 30's °F using hot gas defrosting. This feature must be enabled in the service menu. Unit will not operate below 35 °F.

## CONDENSATION DRAINAGE

It is normal for water to be draining from your heater. This occurs because the evaporator coil condenses the water from the air. The water drains into the base of the unit and out the holes that are located on each side of the heater at the bottom. **Your heater can produce up to 3 gallons of water per hour.** The water created from the condensation will dry up when the heater is shut off.

## HEAT/COOL Models

### Option #1

HEAT/COOL – This will allow your Heat Pump to maintain the temperature in your pool at a constant temperature. If the water temperature gets 2° warmer or colder, the unit will heat or cool the pool until it reaches the desired set point.

Programming Instructions:

1. Enter Sub-Menu
2. Press the "MODE" button to scroll options until screen reads "POOL – HEAT/COOL" (Default "DISABLED").
3. Press the "UP" or "DOWN" to "ENABLE" this feature.

Operation Instructions:

1. Press the "MODE" button; The Display will read "POOL – HEAT/COOL".
2. Press the "UP" or "DOWN" until screen reads "POOL TEMPERATURE SETPOINT".
3. Use the "UP" or "DOWN" arrow until desired temperature is on display.
4. While still in the "POOL TEMPERATURE SETPOINT" screen, press the "MODE" button to set the "DEADBAND" This will regulate how many degrees out until the unit kicks on to heat or cool (Default is 2°).

### Option #2

COOL ONLY - This will allow your Heat Pump to independently heat or cool your pool.

Programming Instructions:

1. Access the service menu by pressing and holding the "UP" and "DOWN" at the same time, until the screen changes to "REMOTE TSTAT" (Default "DISABLED").
2. Press the "MODE" button to scroll options until screen reads "POOL – COOL" (Default "DISABLED").
3. Press the "UP" or "DOWN" to "ENABLE" this feature.

Operation Instructions:

1. Press the "MODE" button; the Display will read "POOL – COOL".
2. Press the "UP" or "DOWN" until screen reads "POOL TEMPERATURE SETPOINT" the unit will cool until it reaches this temperature.

# Heat/Cool with an External Remote



## **WARNING:**



Only use dry-contact relays. Any relay that sends low voltage will damage the heat pump transformer.

\*\* In addition to the external remote's heater relay, a secondary spare dry-contact relay in the controller (external remote) will be required. Any relay that sends voltage will cause the transformer to be damaged in the heat pump.

From the controller's heat pump relay or plug-ins, wire the Heat Pump to the control system for Remote T-stat like normal. Using the Sub-menu, enable "Remote T-Stat". Here you will be able to set the heating temperature for your pool and/or spa on your controller. You will be able to control the Heating Setpoint from your controller.

Wire the secondary spare dry-contact relay in the controller to the spades on the Gulfstream board that are labeled "Heat/Cool".

In the sub-menu, enable the "Remote Heat-Cool" and "Pool Cool" Modes. Return to the main menu and press the Mode Button until "Pool Cool" is displayed on the board. Use the Up/Down arrows on the heat pump to activate the setpoint temperature for the Cooling Mode.

Your remote can be programmed to call the spare relay "Chiller" (see the manual for the controller or have this completed by your pool professional).

When the "Chiller" is activated on the remote, it will over-ride the Heating Mode and begin chilling down to the "Pool Cool" set point on the heat pump. The heat pump will shut off when it meets the cooling set point and will run as needed to maintain the cooling setpoint.

When the chiller is turned off on the controller, the unit will go back to the remote t-stat heating mode. If heat is desired, just make sure the setpoint is higher than the current water temperature.

#### 4 Most Common Service Questions:

1. Is my heat pump leaking water?

The higher the efficiency, the more water the heat pump creates through condensation. Up to 3 gallons per hour will weep from the bottom of the heat pump. See page 12.

2. What is the difference between "NOFLOW", "LOW FLOW" and "WATER FLOW LOCKOUT"?

-"No Flow" is when there is no water flow detected by the internal pressure switch. Check to make sure the circulation pump is on and bypass valves are in the correct position.

-"Low Flow" or "Water Flow HP" is when there is not enough water flow to carry away the heat in your heating system. Pressure will build up in the refrigerant system and the heater will shut down to avoid damage. This most commonly caused by dirty filters or valves in the wrong position.

-"Water Flow Lockout" happens when Low Flow or Water Flow HP happen 3 times. The unit will need to be reset at the breaker. Check all water flow issues above and be sure water is not backflowing after the circulation pump stops for the day (due to a bad check valve or from a solar pool heating system when it drains).

3. My heater is not coming on when I activate it from my remote?

Check the heater in manual mode. Access the sub menu and Dis-able the Remote T-stat. Make sure the set point is higher than the pool temperature. If the heater comes on manually, please call your pool professional to service your control system.

4. If all else fails..

Access the sub menu and scroll until you come to "Reset Defaults". Press the down arrow to restore the Control Board to factory settings.

## CARE & MAINTENANCE

### CLEANING



#### CAUTION:



Make sure all power is disconnected to the heater prior to washing.

There is not much maintenance that needs to be done on your heater. Making sure there is good airflow through the evaporator and proper drainage are the two main tasks. A garden hose with low-pressure water flow can be used to clean the evaporator coil. **DO NOT spray the control box.** Keep all shrubs trimmed away from the unit to allow sufficient airflow. Clean the coil as needed. If located near the ocean, cleaning will need to be done regularly to remove salt and sand. Use a very soft brush avoid bending the coil fins and soapy water to remove any build up.

**Keep the drain holes in the base free of debris to assure proper condensation drainage.**

Your heat pump's cabinet is made from a maintenance-free, rust-free plastic that is UV-resistant. It will last for years and any dirt or dust may be wiped away with a cloth or sprayed off with a water hose. Only use products designed for cleaning plastics.



#### WARNING:



DO NOT USE CLEANERS THAT CONTAIN Chlorine.  
Alcohol based cleaners may damage the plastic.

**Best Practice:** Do not allow the heater to sit unused for prolonged periods. Run the heater for 30 minutes once per month to keep mechanical parts in their best condition.

### WINTERIZING

In areas where freezing conditions are not prevalent and winterizing of pools is not common, allow water to flow through the heater even when not in use.



#### ATTENTION:



**In freezing areas, it is MANDATORY that the water be completely drained from the heater and disconnected from the piping. The heat exchanger must be blown out with air to ensure no water is left in the heat exchanger.**



## TROUBLESHOOTING

A simple test to verify that your heater is functioning is to place your hand above the unit. There should be cool air blowing out the top after time delay has expired. The return water to the pool should be a few degrees warmer than water entering the heater. After about 15 minutes of run time, there should be water draining out of the base of the unit. If you have reason to believe your heater is not functioning properly, follow the troubleshooting guide below. If the unit is still having issues, please call for service.

### **Unit has a blank display:**

Check Breakers, Disconnect or Transformer -

Try to reset the breaker by flipping it off and then back on.

If you still do not get a display on the board, you may need to have an electrician to make sure the breaker or transformer is still in working condition.

### **Unit has water coming out of bottom of unit:**

Turn the Heater off, but allow the Circulation Pump to continue to run -  
Come back after about 1 hour. If the water stops leaking from the bottom of the unit, it was normal condensation.

If water is still coming out of the bottom of the unit, then you may have a water leak inside of the unit. Also, a pool test strip can detect chlorine if a water leak is suspected.

### **Heater is heating slowly or not getting up to temperature:**

Low or restricted water flow through the heater -

You may need to clean or replace the filter.

Check the pool pump to make sure you are getting about 40-50 GPM through the unit. Variable Speed pumps should provide 40-50 gallons per minute (RPM's will vary between brands – 2400 RPM is typically sufficient).

Air leak in pool system -

Repair any air leaks in plumbing.

Pool Pump Run Time -

Make sure you are allowing the circulation pump to run long enough, try to allow unit to run longer.

Strong winds in pool area -

This may cause water to lose a large portion of heat from the wind. Install some type of windbreak around the pool  
Use of a pool blanket will greatly cut down the amount of heat loss you experience and save you money.

### **I see a countdown on my display and my unit is not kicking on:**

Delay is a 2-minute waiting period to allow the unit pressures to balance out. Once the count-down reaches zero, the unit should kick on. If not, the unit may require a new contactor.

### **Unit Displays No Flow or Water Flow HP:**

- Check to make sure the Pool Pump is on and primed -  
If pump is off or not primed, it will not send any water through the system.
- Check any bypass valves -  
Make sure they are not redirecting the water away from the unit. Make sure that you are getting anywhere from 30 GPM to 70 GPM through the unit.
- Check the pool filter to make sure it is clean -  
If filter is dirty then the unit will not receive the correct amount of water. Make sure that the filter is being cleaned or replaced, when it's necessary.

### **Unit Displays Water Flow Lockout:**

- Once the unit has had a Water Flow HP 3 times the unit will lockout -  
Check the same flow issues for No Flow and Water Flow HP.
- Backflow from solar or pool heater below water level -  
Water backflow once the circulation pump stops can activate the pressure switch. Adjust pressure switch as needed or install a flow switch.  
If flow issues have been addressed, hold the down arrow for 5-seconds to reset the lockout.

### **Unit Displays Low Refrigerant Pressure:**

- Unit low-pressure switch was activated -  
Call For service.

### **Unit Displays Max Water Temperature:**

- Check to make sure you do not have a secondary source of heat feeding hot water into the unit -  
If no secondary source of heat, call for service.

### **Unit Displays Water/Evap Sensor Malfunction:**

- Unit Water or Evaporator Sensor needs service -  
Call for Service.

### **Unit is Making a Loud Noise:**

- Check to see if the sound stops after running for a few minutes -  
If it stops making noise within a few minutes, it may be because of the starting position of the compressor. This can occur sometimes and may not need service as long as it corrects itself.  
Look to see if the fan is hitting anything.  
If noise does not stop, call office for service.

### **Remote System not working:**

- Disable Remote T-stat in the sub menu. If heater operates normally have the remote system serviced.

## Electrical Diagram

### Pool Heater Diagram

#### Legend

- Comp...Compressor
- CC...Compressor Capacitor
- DEF...Defrost Temp. Sensor
- FC...Fan Capacitor
- FM...Fan Motor
- HPS...High Pressure Switch
- H2O...Water Temp. Sensor
- LPS...Low Pressure Switch
- M1...Main Contactor
- RV...Reversing Valve
- T1...Transformer
- WPS...Water Pressure Switch

High Voltage  
Field Connection From Disconnect  
208-230/1/60  
220-240/1/50

Red Wire  
Use for 208 V  
Application

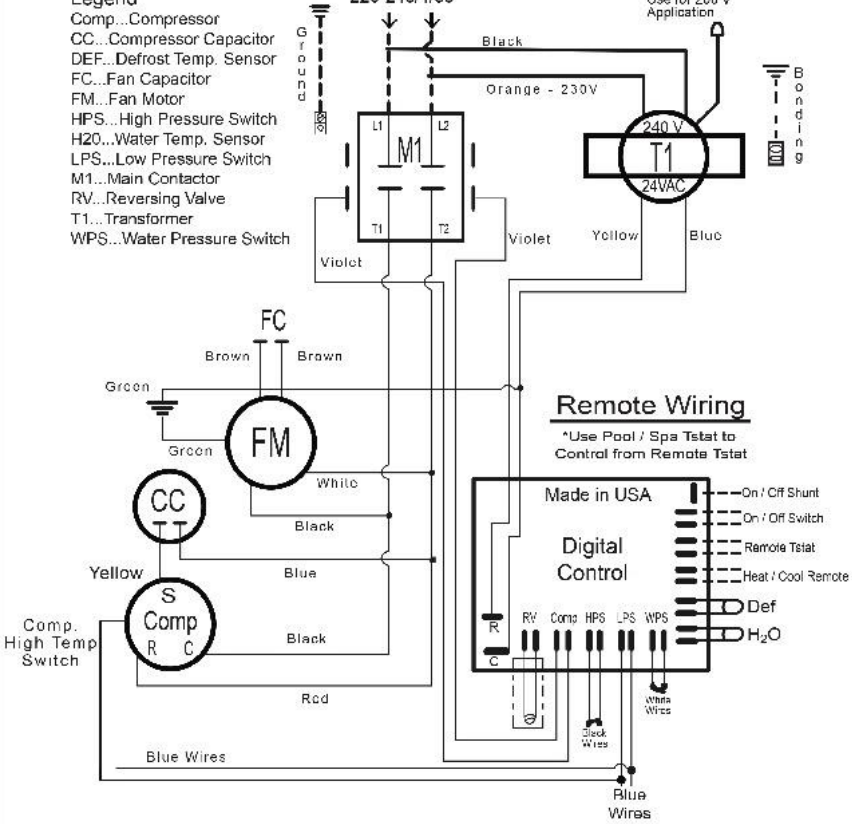

FS1

Notes:



## **WARNING:**



Non-authorized service may not be covered under warranty.

## **SERVICE**

All warranty service must be handled by an Authorized Service Center. Warranty costs may not be covered if a non-authorized service representative does service. Do not return the heater to your dealer, as they do not provide service. Before calling for assistance or service, please check the Troubleshooting section of this manual or call your dealer. This may save you the cost of a service call. If you still need help, follow the instructions below.

**Schedule service online at:**  
[gulfstreamheatpump.com](http://gulfstreamheatpump.com)

Service can also be obtained by calling us at:  
(239)567-0009 or (954) 318-6900

When calling for help or service please provide a detailed description of the problem, your heater's complete serial number and the date purchased. This information will help us respond properly to your request.

**Keep a copy of the sales receipt showing the date of purchase. Proof of purchase will assure you of in-warranty service.**

**REGISTER ONLINE AT:**  
[gulfstreamheatpump.com/register](http://gulfstreamheatpump.com/register)

**MANUFACTURED BY:**  
G & F MANUFACTURING, INC.  
7902 INTERSTATE COURT  
NORTH FORT MYERS, FL 33917  
(239)567-0009